



WINDOWS | TERRACE DOORS | EXTERIOR DOORS
TIMBER

CONTINUOUS INNOVATION since 1994

- ✓ Quality
- ✓ Innovations
- ✓ Cutting-edge technologies
- ✓ Experience
- ✓ Professional network of business partners
- ✓ International presence

Since 1994 DAKO has developed an unrivalled reputation for innovation, quality and workmanship as a manufacturer of a wide range of high-performance PVC, timber, aluminium and steel products that meet global Clients' needs.

The company's growing success can be attributed to its continually modernized production process, cutting-edge technologies and continuous adaptation to changing Client requirements. DAKO improves its employee competencies, continuously invests in company development and successfully expands into new markets. The company has sold millions of windows worldwide and boasts a record of strong Client satisfaction.

We currently serve the following countries:

Germany, Italy, Norway, Sweden, France, Belgium, Czech Republic, Slovakia, Poland, Luxembourg, Spain, Israel, Tunisia, Mexico, Japan and many others.

Comprehensive range of products - find out more

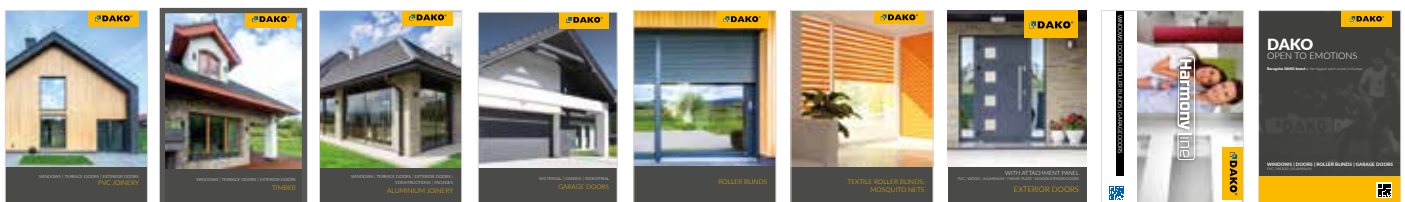

TABLE OF CONTENTS

WAY TO QUALITY	4
----------------	---

WINDOWS	6
DDA-78 series	7
DDF-78 series	8
DDR-78 series	9
DDF-78 AL series	11
DDF-92 series	12
DDR-92 series	13
DDF-68/DDR-68 series	14
DDF-92 AL/DDF-68 AL series	16
Quick comparison of series	18
Fittings	20
Glasses	22
Handles	23

TERRACE DOORS	24
Lift-sliding HST	25
Tilt-sliding HKS	26

EXTERIOR PLATE DOORS	28
Models	29
Door configurator	33
Construction	34
Standard equipment	36
Optional equipment	37

EXTERIOR FRAME-PLATE DOORS	38
Models	39
Construction	42
Standard equipment	44
Optional equipment	45

GET FAMILIAR WITH OUR TIMBER	46
------------------------------	----

COLOUR OF TIMBER PRODUCTS	48
---------------------------	----

HARMONYLINE - OUR IDEA, YOUR PLACE IN THE WORLD	52
---	-----------

WAY TO QUALITY

Explore the way to DAKO quality. Learn how proceeds the process which aims at meeting the individual expectations of every single customer.

Analysis of technological opportunities

The technological progress gives the joinery producers an increasing number of possibilities. To meet growing expectations of customers the manufacturers must constantly follow technological innovations and modify the range of products by introducing the solutions that best meet the users' needs. DAKO company has a team of qualified and experienced engineers forming the Product Development Department, which is responsible for products development.

Selection of the best components

All products are made of components supplied by producers recognised by the worldwide markets. The highest quality PVC profiles, timber of optimum physical and mechanical properties and aluminium systems used in the most prestigious projects guarantee reliability and durability of DAKO products. Glasses and fittings from renowned suppliers ensure maximum energy saving, security and functionality of our products.

Innovative technological park

Combining components in the efficiently operating system requires cutting-edge machines. DAKO joinery is produced in the technological park which is one of the most innovative object of this type. The precise, numerically-controlled woodworking, milling, welding machines and saws operate in three production halls with total surface of 26 300 m². The park also has a testing laboratory, powder paint shop and profile edge banding shop, ensuring full control over product finish quality.

Experienced and qualified staff

The production process is carried out and controlled by qualified specialists and engineers having long job seniority. Regular trainings and tests ensure a high level of competencies, required to construct complex windows, modern terrace doors with large glazing and other advanced solutions.

Adherence to stringent standards

In order to ensure the highest production standards, DAKO undergoes assessment, control and certification procedures. They result in authorisations, certificates and rights to use the marks confirming products quality. DAKO has, among others, Q-Zert certificate issued on the base of the audit carried by the IFT Rosenheim, the most important research centre in Europe. Additionally, DAKO products are compliant with the European Standard CE, and the authorisations from the suppliers of components confirm that they meet rigorous safety requirements.

Quality control

DAKO has a department responsible for quality control, that is an important link in the production process. Both received components and ready-made products undergo detailed controls. Each production line has its own controllers who supervise specialists' work. The additional control is carried out randomly by the patrols that inspect the production process on all lines.

Transport fleet

Windows, as the exceptionally sensitive products need to be appropriately treated during transport. The own vehicle fleet allows for complete control over the loading, transport and unloading of our products. Due to DAKO own vehicles we are certain our products reach the customers preserved intact. Additional benefit resulting from our own transport fleet are fixed, regular delivery times that influence the date of order completion.

Competent sales advisors in the showrooms

The final step in the way to DAKO quality is the showroom. Only professional guidance and correct assesment of the building situation can make the joinery fulfil its function and meet the customers' expectations. DAKO Commercial Partners are the experts with the extensive knowledge and experiance that allow to meet the requirements of contemporary architecture.





WINDOWS



BEAUTY AND ELEGANCE



ENERGY EFFICIENCY



SECURITY



COMFORT



INNOVATIONS

DDA-78

Innovation, modern design and wide scope of possibilities

- ✓ Highest quality of timber window of aluminium profile
- ✓ The choice from 9 different shapes of aluminum profile from the outside
- ✓ Innovative dry glass installation
- ✓ Glass placed on seals

Carefully selected wood combined with aluminium profile ensures excellent thermal and acoustic insulation of the window along with durability and resistance to weather conditions.



DDA-78 Classic Thermo

DDA-78 windows series



Classic Thermo



Classic



Classic 0.5



Linear



Softline



Quadrat



Quadrat FB



Retro



Integral

DDF-78

Noble beauty of wood, excellent thermal insulation

- ✓ High thermal and acoustic insulation
- ✓ Optimal performance parameters
- ✓ Usage comfort

The profile line goes along with the current architectural trends and perfectly matches modern constructions. The usage of triple glazing and noble gas filling guarantees excellent thermal and acoustic insulation as well as provides the highest usage comfort.



DDF-78

CHARACTERISTICS

- Profile of modern line
- Pine, larch and Meranti wood
- 3 retractable seals



DDR-78

Elegance, beauty, unique style

- ✓ Ornamental milling
- ✓ High technical parameters
- ✓ Stylish character

Decorative milling of sashes' external edges and glazing beads not only gives the windows an elegant and universal character but also enhances unique style of building.

Wide range of finishing colours allows for unlimited possibilities of design as well as matching the windows to the individual building character.



DDR-78

CHARACTERISTICS

- Stylised profile line
- Pine, larch and Meranti wood
- 3 retractable seals





DDF-78 AL

Warmth, style, durability

- ✓ Resistance to weather and mechanical damages
- ✓ Energy-saving and thermal comfort
- ✓ High quality standard and modern style

Energy-efficient timber windows with aluminium cladding ensure excellent thermal and acoustic insulation along with durability and resistance to weather conditions. Natural beauty of wood strengthened with aluminium cladding ensures prestigious design, remarkable durability, and also highlights unique style of building.



DDF-78 AL

- High quality standard and modern style



DDF-78 AL | RAL 7016

DDF-92

Naturally beautiful warmth

- ✓ Maximum thermal and acoustic insulation
- ✓ Awarded with the Golden Emblem Quality International
- ✓ Natural beauty of wood in modern design

The most prestigious series of DAKO timber windows which gain their exceptional value due to the carefully selected natural raw material. Rounded shape of the profile and glazing bead makes the windows elegant and universal. The cutting-edge technology used in windows production has gained the recognition among the customers, confirmed by the awards granted by the industry experts.



DDF-92

THE WARMEST TIMBER WINDOWS IN POLAND ACCORDING TO LTB* RESEARCH

- Awarded with Golden Emblem Quality International as a product of the highest quality



DDF-92 | Chocolate brown



U_w
0,65 w/m²K*

*glass: 4/12/4/12/4/12/4; gas: krypton; warm edge; dimensions of the window: 1230 mm x 1480 mm

DDR-92

Stylish and energy-saving

- ✓ Maximum thermal and acoustic insulation
- ✓ Ideal for buildings of historical and rustical character
- ✓ Sophisticated beauty of natural wood

A sophisticated series of windows with enriched profile line giving the products a unique and subtle appearance. It enables the energy-saving technologies to be applied in the buildings requiring an individual treatment. The windows are ideal for historical architecture and perfectly emphasize a warm character of rustical interiors.



DDR-92

APPLICABLE IN:

- Stylised objects
- Historical architecture
- Traditional and rustical buildings

DDR-92 | Pine



DDF-68/DDR-68

Natural beauty with extensive equipment

- ✓ Attractive price
- ✓ Very good thermal and acoustic insulation
- ✓ 2 visual versions

The appearance of DDF-68 and DDR-68 series fully corresponds to the aesthetics of DDF-92 and DDR-92 windows. The attractive price results from the use of 68 mm thick profile. The source of series popularity is its extensive equipment guaranteeing a very good thermal and acoustic insulation.



DDF-68

Modern edge of the profile



DDR-68

Ornately milled edge of the profile





Choose a species of wood appropriate for your needs. Check more on page 46.

Get familiar with **our timber**

DDF-92 AL/ DDF-68 AL

Exceptional aesthetics, maximum durability

- ✓ Naturally beautiful wood from inside
- ✓ Aesthetics and durability of aluminium from outside
- ✓ Extensive equipment in standard

The usage of exterior aluminium cladding in DDF-92 and DDF-68 timber windows has resulted in creating a distinctive product of the exceptional values. The noble beauty of wood enriches the interiors making them prestigious and elegant, whereas the aluminium cladding allows for obtaining almost any shape of the elevation.

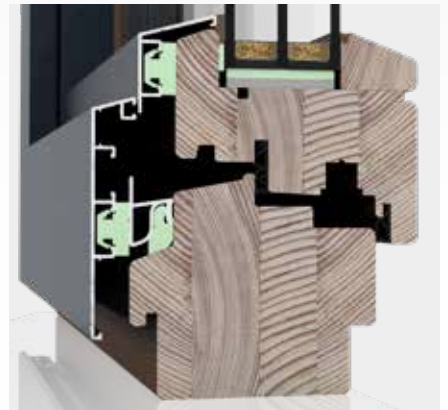

DDF-92 AL

ALUMINIUM CLADDING

- Wide variety of colours, textures and patterns
- Aluminium alloy of high quality
- Durability of windows even 30 years longer

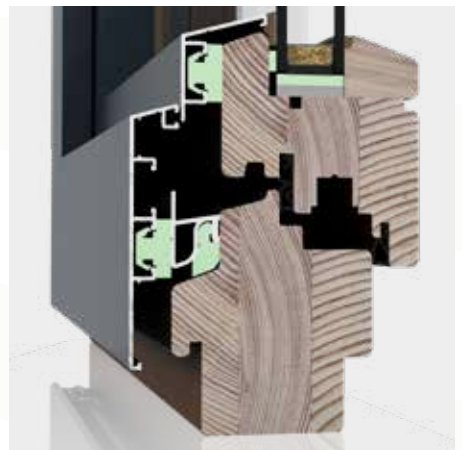

DDF-68 AL

ALUMINIUM CLADDING

- Various possibilities of appearance shaping
- Protection against atmospheric factors

DDF-92 AL | RAL 3005 | Teak











PROFILE		SYSTEM			
			DDA 78	DDF-78	DDF-78 AL
PROFILE					
PROFILE THICKNESS Greater profile thickness provides better thermal insulation			78 mm	78 mm	78 mm
PERIMETER-SEALS Higher number of seals improves window tightness			3	3	3
HANDLE					
HANDLE TYPE Handle influences the aesthetics of windows and may increase the security of the householders			made of aluminium: white or brown	made of aluminium: white or brown	made of aluminium: white or brown
STANDARD GLASS PACKET					
GLASS PACKET Higher number of chambers in glass packet provides better thermal insulation			3-glass packet, 4x14x4x14x4	3-glass packet, 4x14x4x14x4	3-glass packet, 4x14x4x14x4
U GLASS VALUE Lower U glass value provides better thermal insulation			0,6 W/m²K	0,6 W/m²K	0,6 W/m²K
FILLING WITH ARGON Argon gas in inter-pane voids improves thermal insulation			✓	✓	✓
STANDARD FITTING					
FITTING TYPE Modern fittings are infallible and give the windows exceptionally elegant appearance			Standard	Standard	Standard
CHOSEN SPECIAL FITTINGS					
TILT FIRST			●	●	●
INVISIBLE HINGES			●	●	●
CHOSEN ENERGY EFFICIENT SPECIAL GLASSES					
3-glass packet 4/18/4/18/4 Warmth and extra lighting	(U _g = 0,5 W/m²K) 		×	×	×
3-glass packet 44.4/14/4/14/4 Security and protection	(U _g = 0,6 W/m²K) 		×	×	×
3-glass packet 4/14/4/14/33.1 Warmth and security	(U _g = 0,6 W/m²K) 		●	●	●
3-glass packet 44.2/12/6/12/6 Silence and security	(U _g = 0,7 W/m²K) 		●	●	●
4-glass packet 4/12/4/12/4/12/4 Maximum energy saving	(U _g = 0,3 W/m²K) 		×	×	×

Key: ✓ - standard element ● - optionally available element × - unavailable element

QUICK COMPARISON OF SERIES

							
	DDR-78	DDF-92	DDR-92	DDF-68	DDR-68	DDF-92 AL	DDF-68 AL
	78 mm	92 mm	92 mm	68 mm	68 mm	92 mm	68 mm
	3	3	3	3	3	3	3
	made of aluminium: white or brown	made of aluminium: white or brown	made of aluminium: white or brown	made of aluminium: white or brown	made of aluminium: white or brown	made of aluminium: white or brown	made of aluminium: white or brown
	3-glass packet, 4x14x4x14x4	3-glass packet, 4x16x4x16x4	3-glass packet, 4x16x4x16x4	2-glass packet, 4x16x4	2-glass packet, 4x16x4	3-glass packet, 4x16x4x16x4	2-glass packet, 4x16x4
	0,6 W/m²K	0,5 W/m²K	0,5 W/m²K	1,0 W/m²K	1,0 W/m²K	0,5W/m²K	1,0 W/m²K
	✓	✓	✓	✓	✓	✓	✓
	Standard	Standard	Standard	Standard	Standard	Standard	Standard
	●	●	●	●	●	●	●
	●	●	●	●	●	●	●
	×	●	●	×	×	●	×
	×	●	●	×	×	●	×
	●	●	●	×	×	●	×
	●	●	●	×	×	●	×
	×	●	●	×	×	●	×

FITTING COMPONENTS

CHECK AND COMPARE THE FITTING COMPONENTS		Standard	INVISIBLE HINGES	TILT FIRST
MICROVENTILATION Allows to release the window and provides better air circulation		✓	✓	✗
ANTI-BURGLARY "MUSHROOM" BOLTS ALONG THE ENTIRE SASH PERIMETER Prevent the window from being pried open		✗	✓	✗
ANTI-BURGLARY CATCHES IN RU SASH Prevent the window from being pried open		1	1	1
ANTI-BURGLARY CATCHES IN R OR U SASH Prevent the window from being pried open		●	●	●
ADDITIONAL ANTI-BURGLARY CATCHES Greater amount of the catches makes the window more secure		●	●	●
HANDLE ROTATION BLOCKADE WITH SLIDING Prevents the tilt sash from being opened		✓	✓	✗
BK BALCONY LATCH Maintains closed sash without using the handle		●	●	●
BALCONY LATCH AND HANDLE ROTATION BLOCKADE WITH SLIDING Combines the functions of balcony latch and handle rotation blockade		●	●	✗
TBT HANDLE Prevents the sash from being opened without the key allowing only for its tilting		✗	✗	✓
ANTI-DRAUGHT LOCK Prevents the sash from hitting the frame		✓	✓	✓

Sashes indication:

R - turn | U - tilt | RU - tilt&turn

✓ - standard element

● - optionally available element

✗ - unavailable element





FITTING FUNCTIONS



TILT FIRST

The handle set horizontally tilts the window, whereas the full opening requires the handle to be set vertically. In connection with TBT handle, the fitting allows to limit the possibility of window opening. Without the key the window can only be tilted what eliminates the risk of falling out.



INVISIBLE HINGES

When the sash is closed the hinges are invisible what gives the windows exceptionally elegant appearance and facilitates keeping it clean. A great advantage of the fitting is an easy regulation without using the tools.

MOVEMENT SENSORS



The sensors integrated with the fitting transmit the information of window closing or opening to the selected systems activating them accordingly to the user's expectations.

USAGE

Air-conditioning – window opening causes automatic deactivation of the air-conditioners and gives savings resulting from limiting inefficient air-conditioning operation.

Heating – sash opening causes deactivation of the heater under the window, therefore, the costs of inefficient heating can be avoided.

Alarm system – information of the window status is transmitted to the alarm system, activating the alarm, if needed.

- Three-function sensors distinguish the closed, tilted and opened window so the alarm system can be protected during ventilation.
- Sensors do not react to movement what allows them to be active when residents and animals are at home.
- Sensors are invisible from the outside and, therefore, the burglars cannot prepare themselves for attempting to disarm them.

GLASSES

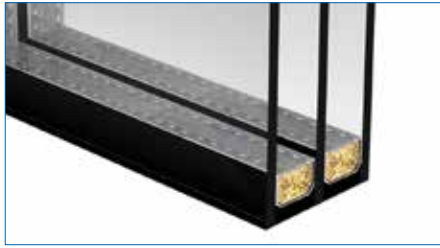

3-glass packet 4/14/4/14/4
EXTRA THERMAL INSULATION

Improves thermal insulation of windows. Total thickness of glass packet allows for its installation in all windows, regardless of the profile thickness.

TECHNICAL PARAMETERS

Total solar energy transmittance: **g=51%**

Light transmittance: **Lt=72%**

Thermal permeability: **U_g = 0,6 W/m²K**

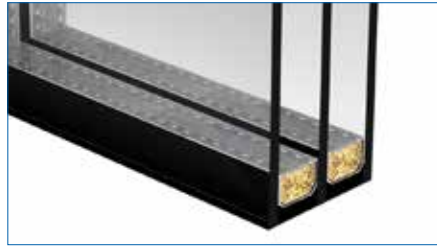

3-glass packet 4/18/4/18/4
WARMTH AND EXTRA LIGHTING

Provides greater permeability of solar energy and light as well as improves heating and lighting of the interior.

TECHNICAL PARAMETERS

Total solar energy transmittance: **g=50%**

Light transmittance: **Lt=70%**

Thermal permeability: **U_g = 0,5 W/m²K**

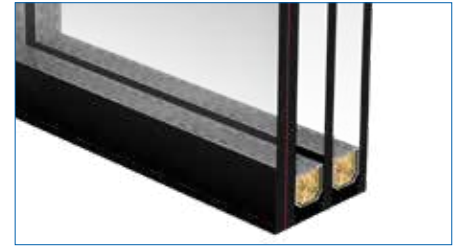

3-glass packet 44.4/14/4/14/4
SECURITY AND PROTECTION

Characterised by high impact resistance and additionally equipped with a filter protecting against high-energy fractions of sunlight and UV radiation.

TECHNICAL PARAMETERS

Safety class: **P4**

Total solar energy transmittance: **g=45%**

Light transmittance: **Lt=69%**

Thermal permeability: **U_g = 0,6 W/m²K**

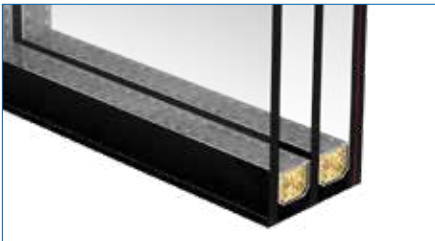

3-glass packet 4/14/4/14/33.1
WARMTH AND SECURITY

Internal glass is covered by foil, therefore, broken glass does not disintegrate what excludes the risk of injury.

TECHNICAL PARAMETERS

Safety class: **B2B**

Total solar energy transmittance: **g=47%**

Light transmittance: **Lt=70%**

Thermal permeability: **U_g = 0,6 W/m²K**



3-glass packet 44.2/12/6/12/6
SILENCE AND SECURITY

Glass construction ensures high level of protection against burglary and increased acoustic insulation.

TECHNICAL PARAMETERS

Safety class: **P2**

Acoustic insulation coefficient **R_w = 39dB**

Thermal permeability: **U_g = 0,7 W/m²K**

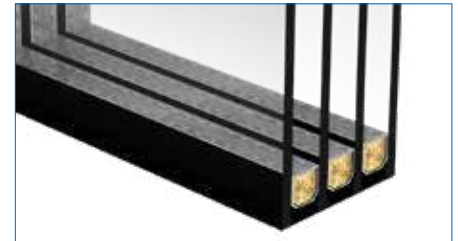

4-glass packet 4/12/4/12/4/12/4
MAXIMUM ENERGY SAVING

Three chambers of 4-glass packet guarantee maximum thermal insulation making this packet an ideal product for passive houses.

TECHNICAL PARAMETERS

Thermal permeability: **U_g = 0,3 W/m²K**

Total solar energy transmittance: **g=33%**

Light transmittance: **Lt= 48%**

WARM-EGDE SPACERS

Warm-egde spacer increases thermal performance of the window.



Chromatech

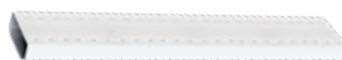

White



Light grey



Dark grey



Light brown



Dark brown



Black

HANDLES



HANDLE 1006
(standard)



HANDLE 1007



HANDLE 1009



HANDLE 1012



HANDLE 1030



HANDLE 1033



**SECUSTIK®
LUKSEMBURG HANDLE**

Protected by the mechanism preventing the window from being opened from the outside.



**SECUSTIK®
NEW YORK HANDLE**

Protected by the mechanism preventing the window from being opened from the outside.



**SECUSTIK®
LUKSEMBURG HANDLE
WITH KEY**

Opening Secustik® handle with key requires the key to be used what reduces the risk of accident and prevents the window from being opened from the outside.

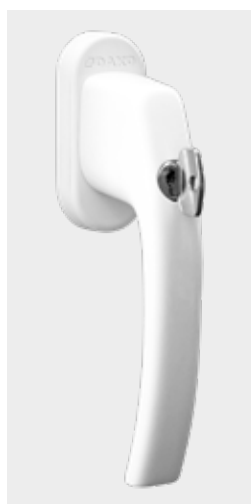

1006 HANDLE WITH KEY

Window opening requires the key to be used what reduces the risk of an accident and prevents the window from being opened from the outside.



**1006 HANDLE WITH
BUTTON**

Window opening requires the lock release with the button what reduces the risk of an accident and prevents the window from being opened from the outside.

COLOURS



White



F9 - Titanium



F1 - Silver matt



Brown - RAL 8707
(colour available only for secustik handles)



Brown - RAL 8019
(does not apply to secustik handles)



F4 - Old gold



F2 - Champagne - (colour available only for secustik luksemburg and new york handles)



TERRACE DOORS



SPACE



ELEGANCE



COMFORT

Lift-sliding HST doors

Space, prestige, comfort

- ✓ Convenient opening and closing
- ✓ Maximum prestige and elegance
- ✓ Threshold flush aligned with floor

The door operates on the basis of innovative lift-sliding opening system that gently raises the sash moving on special rollers. Therefore, sliding the door is effortless. The door threshold can be flush aligned with the floor surface from inside. The system enables exceptionally large glazing to be constructed what allows for transmission more daylight to the interior making it spacious and prestigious in character.

TECHNICAL PARAMETERS:

 Max. weight of sash: 300 kg	 Max. surface of sash: 6,5 m²
 Max. height of door: 2,6 m	 Max. width of sash: 6 m

There are various opening schemes available for door constructions. Doors available in DDF-68, DDF-78, DDF-68 AL, DDF-78 AL, DDA-78 series.



OPTION: ALUMINIUM CLADDING

Opening types:



Sliding in horizontal plane

-  It allows the movable sash to be fully opened.



Threshold flush aligned

-  The alignment of the threshold with the inner floor level, available as an option, eliminates an obstacle in circulation area.



Automatic door (option)

-  Remote-controlled door opening and closing

Tilt-sliding HKS doors

Comfort and elegance at reasonable price

- ✓ Possibility of tilting the movable sash
- ✓ Very attractive price

Full functionality and operational comfort of the door resulting from the possibility to easily slide and tilt the movable sash. The simplicity of system operation allows to obtain very reasonable price and, therefore, the elegant and trendy large glazing is accessible to each home.

TECHNICAL PARAMETERS:

- | | |
|------------------------------------|---|
| Max. weight of sash: 160 kg | Max. surface of sash: 3m² |
| Max. height of door: 2,4 m | Max. width of sash: 3 m |

There are various opening schemes available for door constructions. Doors available in DDF-68, DDF-78, DDF-92, DDF-68 AL, DDF-78 AL, DDF-92 AL, DDA-78 series.

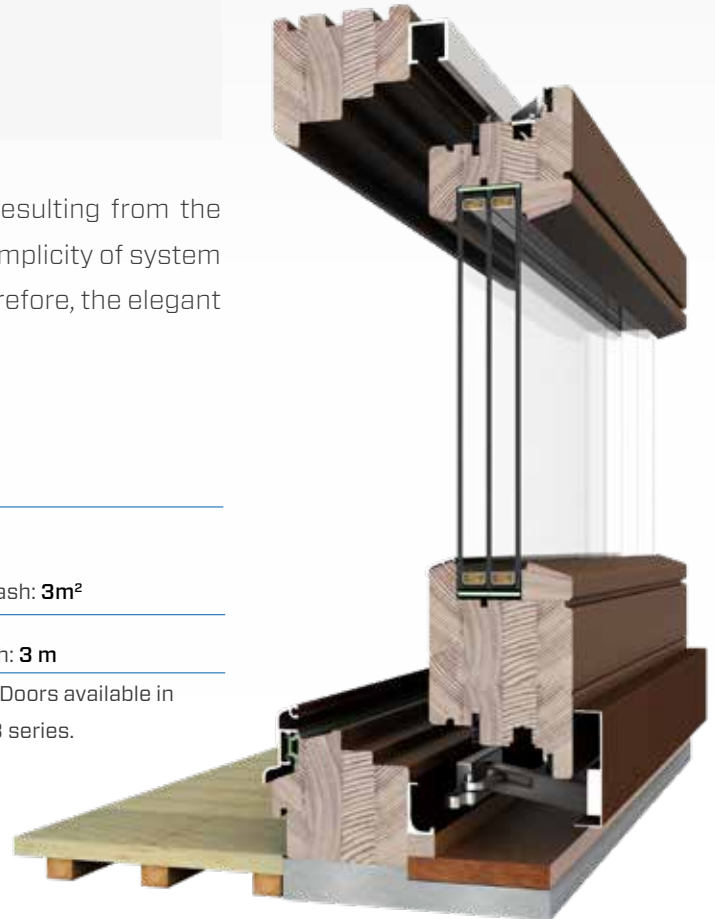

DDF-92

Opening types:



Sliding in horizontal plane

It allows the movable sash to be fully opened.



TILTING

It allows the movable sash to be tilted along the upper edge. It enables proper ventilation of rooms and air circulation.





EXTERIOR PLATE DOORS



MODERNITY



SECURITY



WARMTH

GROUP 1



01.01 TIRANO



01.02 MEVA



01.03 SCALA



01.04 NOEL



01.05 GALLA



01.06 ELIGIA



01.07 TALA



01.08 BONA



01.09 AUREA



01.10 ANDREA



01.11 SAFIR



01.12 CANIS

GROUP 2



02.01 MAURA



02.02 OLIMPIA



02.03 MELA



02.04 MELISA



02.05 KASJOPEA



02.06 ZOLA



02.07 FABIA



02.08 SOURIS



02.09 SOTERA



02.10 KORA



02.11 FELIX



02.12 LUX

GROUP 3



03.01 PERLA



03.02 IDALIA



03.03 OMBRA



03.04 ARGEA



03.05 DALIA



03.06 ALMA

GROUP 4



04.01 TAIDA



04.02 SABANA



04.03 RESTINGA



04.04 KEIRA



04.05 FEBA



04.06 THELON

GROUP 4



04.07 DORA



04.08 NICETA



04.09 BONITA



04.10 PECOS



04.11 ALBA



04.12 TULIA

GROUP 5



05.01 EUNIKA



05.02 NILA



05.03 CAURA



05.04 ZOE



05.05 FOTYNA



05.06 ALLA



06.01 LILA



06.02 STELLA



06.03 LIGIA



06.04 GLORIA



06.05 NIMFA



06.06 OFELIA

DAKO DOOR CONFIGURATOR

YOUR POSSIBILITIES



- ✓ Visit www.dako.eu and click on **door configurator** in door section
- ✓ Design the door of your dream
- ✓ Make your dreams come true

Presented pictures are for reference only. Due to the differences in usage of particular materials (aluminium, timber, PVC), the same models made of different materials may vary and differ from presented pictures.

Construction

Due to the attachment panel, the sash of the door forms the unitary surface.

Glass

THERMAL INSULATION

92 mm: 4-GLASS PACKET
33.1/16/4/20/4/14/33.1 Ug=0,5 W/m²K

78 mm: 3-GLASS PACKET
33.1/20/4/20/33.1 Ug=0,5 W/m²K

68 mm: 3-GLASS PACKET
33.1/14/4/16/33.1 Ug=0,5 W/m²K

Frame



WARMTH AND SECURITY

High-quality, layer-glued meranti timber of very good technological properties.

Available wood species: meranti

Threshold



PROTECTION AGAINST COLD

Low threshold, made of aluminium, with thermal insert. Height 20 mm.

Sash



PRESTIGE AND THERMAL INSULATION

Timber with polyurethane filling, covered by 9 mm-thick modified, waterproof Okume plywood.



- Standard dimensions: 1100 x 2100 mm
- Installation depth: 68, 78 or 92 mm
- Inward or outward opening

RESULTS MATTER!



1



Water resistance



900 Pa

The door keeps water resistance under wind pressure of almost 140km/h, whose power is defined as causing „great havoc”. Due to its exceptional parameters, the door provides reliable protection against storms and rainfall with a severe wind.

2

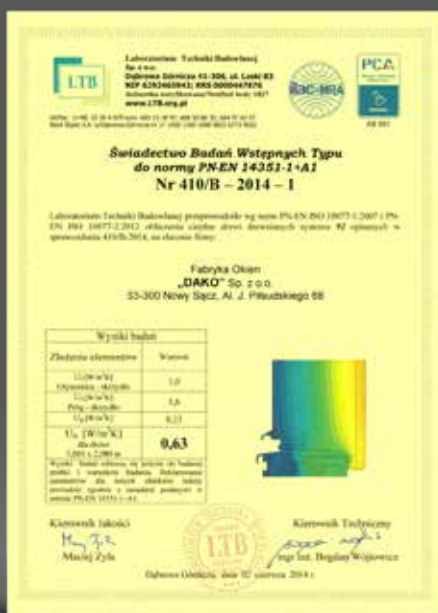

Thermal insulation



$U_d = 0,63 \text{ W/m}^2\text{K}$

The door has the exceptional heat transfer coefficient what guarantees the householders maximum protection against cold.



The results of research conducted on the door 92 mm thick of dimensions: 1065 x 2080 mm at Laboratorium Techniki Budowlanej in Dąbrowa Górnicza.

Standard equipment

A solid basis for unique aesthetics of DAKO doors is the advanced equipment that provides the householders with warmth, security and the reliable operation of doors for a long time.



✓ **92/78/68 mm**
AUTOMATIC LOCK SYSTEM Z-TF

- Six closing elements

The door security is guaranteed by the multipoint lock system that provides the adjustment of the sash to the frame.

- Installation of the lock system along the entire height of sash

The invisible fitting notch provides the elegant appearance of the opened door.

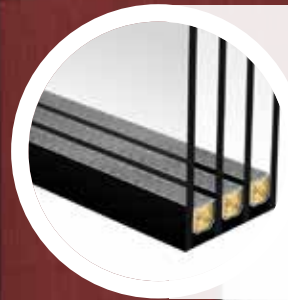

✓ **4-GLASS PACKET**

92 mm: 4-GLASS PACKET
4x18x4x18x4x18x4

78 mm: 3-GLASS PACKET
4/22/4/22/4

68 mm: 3-GLASS PACKET
4x16x4x18x4

✓ **HANDLE ON A LONG HANDLE PLATE**

Standard colours: brown
Optional colours: white, silver (F1), old gold (F4)



✓ **INSERT**

anti-burglary C class insert with key ring



✓ **OVERHEAD HINGE**

Standard colours: brown
Optional colours: white, silver (F1), old gold (F4)



Optional equipment

✓ INSERTS

- Insert of C class security (standard or with “butterfly”)

✓ SELF-CLOSER

- Provides automatic and controlled sash back of door to the closed position



✓ HANDLE ON DIVIDED HANDLE PLATE WITH ROSETTE

- Colours: white, silver (F1), old gold (F4), stainless steel, brown.



KFD-2



KFD-1D



KFD-2D



✓ GRIPS

- P-10** | Available length in mm: 580, 800, 1000, 1200
○ | 1400, 1500, 1600, 1800 | ○
- Q-10** | Available length in mm: 580, 800, 1000, 1200
□ | 1400, 1500, 1600, 1800 | □

✓ GLASS

- 2/B/2 - safe glass with foil
- P2 of increased protection against breaking
- P4 of increased protection against breaking
- Sandblasted
- Ornamental
- Reflective
- With warm-edge spacer

*Do you need different glass?

Contact us - www.dako.eu

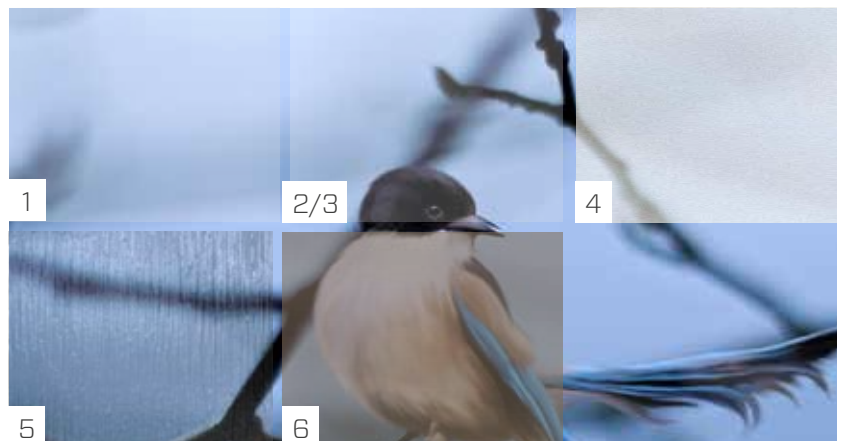



EXTERIOR FRAME-PLATE DOORS



CLASSIC



SECURITY



WARMTH



1 ENA



2 IDA



3 BELLA



4 SIMA



5 TIRA



6 KENNA



7 KANSAS



8 BOSTON



9 CHICAGO



10 HAVANA



11 BAGDAD



12 MEXICO



13 ATLAS



14 ONTARIO



15 PANAMA



16 SAHARA



17 LONDON



18 PARYŻ



19 SEVILLA



20 RUFIC



21 USSON



22 EVOL



23 CAMON



24 YVOIRE



25 SEMUR



26 MORESTEL



27 ARLES



28 VERO



29 MAGNUS



30 BRUNO



31 OSCAR



32 OLIVER

Construction

Frame-plate door construction provides it with classic and nice appearance.

Insulating panel



WARMTH AND DURABILITY

Filled with polyurethane foam that guarantees the highest thermal insulation, covered with natural veneer.

Glass



THERMAL INSULATION

92 mm: 3-GLASS PACKET
4/16/4/16/4/

78 mm: 3-GLASS PACKET
4/14/4/14/4

68 mm: 2-GLASS PACKET
4/16/4/

Frame



WARMTH AND SECURITY

High-quality, layer-glued pine, meranti or larch wood of very good technological properties.

Available wood species:
meranti, pine, larch

Threshold



PROTECTION AGAINST COLD

Low threshold, made of aluminium, with thermal insert.
Height 20 mm.

Sash



QUALITY AND TECHNOLOGY

High-quality, layer-glued timber.



- Installation depth 68, 78 or 92 mm
- Inward or outward opening



Standard equipment



✓ 92/78/68 mm
AUTOMATIC LOCK SYSTEM Z-TF

- Automatic closing. Security without the need to close the door with key.
- Six closing elements. The door security is guaranteed by the multipoint lock system that provides the adjustment of the sash to the frame.
- Installation of the lock system along the entire height of sash. The invisible fitting notch provides the elegant appearance of the opened door.



✓ 92/78/68 mm
HANDLE ON LONG PLATE

- Standard colours:
white or silver (depending on the door colour).
-
- Optional colours:
brown, silver (F1), old gold (F4), stainless steel.

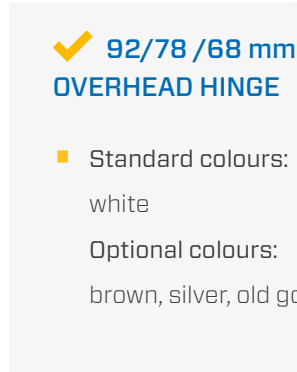

✓ 92/78 /68 mm
OVERHEAD HINGE

- Standard colours:
white
- Optional colours:
brown, silver, old gold



✓ 92/78/68 mm
INSERT

with key or butterfly.

Optional equipment

✓ INSERTS

- C type insert of increased security (standard or with “butterfly”).

✓ SELF-CLOSER

- Provides automatic and controlled sash back of door to the closed position.



✓ HANDLE ON DIVIDED HANDLE PLATE WITH ROSETTE

■ Colours:

white, silver (F1), old gold (F4), stainless steel, brown.



KFD-2



KFD-1D



KFD-2D



✓ GRIPS

- P-10 | Available length in mm: 580, 800, 1000, 1200
○ | 1400, 1500, 1600, 1800 | ○
- Q-10 | Available length in mm: 580, 800, 1000, 1200
□ | 1400, 1500, 1600, 1800 | □

✓ GLASS

- 3-glass packet 4/18/4/18/4
- 3-glass packet 44.4/14/4/14/4
- 3-glass packet 4/14/4/14/33.1
- 3-glass packet 44.2/12/6/12/6
- 4-glass packet 4/12/4/12/4/12/4

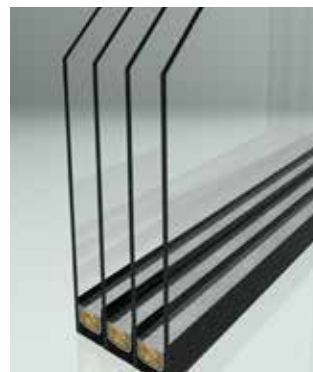

Get familiar with our timber

When it comes to the timber joinery, the key to the success is an appropriate choice and treatment of the raw material. In its production DAKO uses the high-quality scantlings of pine, larch or meranti. Carefully selected material goes through advanced technology process in the innovative machine park, where it is supervised by the qualified specialists with long-term professional experience.



DAKO timber products are certified by PEFC - the world's largest forest certification system. Due to this, we can sell the ecological products made of wood from sustainable managed forests.

PEFC (Programme for the Endorsement of Forest Certification Schemes) is an international non-profit, non-governmental organization dedicated to promoting Sustainable Forest Management (SFM) through independent third-party certification.



PEFC certificate for DAKO timber products confirms that wood and the products made of this wood come from properly managed forests. A number of requirements connected to a full respect of the principles of forest management based on the ecology and sustainable development is the condition upon which the certificate is granted.

Wood species

Solid meranti



cross-section

Precious wood of Asian origin with excellent technological properties. Used as a raw material increases prestige of finished products. Exotic structure of rings, unprecedented among domestic wood species is its distinguishing feature and major reason of its popularity.

Solid pine



cross-section

Well-trying in production of joinery and traditionally used in window construction. Guarantees very good mechanical properties and high durability of products. The wood has distinctive structure of the conifer. A strong advantage of pine is the possibility of achieving the best value of the product at the reasonable price.

Finger joint pine



longitudinal section

Finger joint pine scantling retains utility values of the wood used to its production and has distinctive structure of the conifer. Characterised by very high stiffness and resistance to bending. The usage of finger joint scantling is reflected in very attractive price of the products.

Solid larch

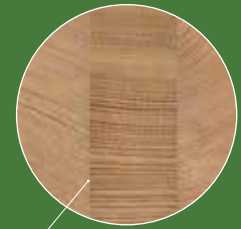

cross-section

Extremely resistant wood, as solid as oak and of twice higher refractoriness than pine. As the only species does not rot in seawater. In direct contact with the ground, in extremely adverse conditions it achieves the lifetime exceeding 15 years. Characterised by exceptionally dense wood grain.

Production process

Varnish



DAKO windows are three-layer varnished by applying PowerFeed - the innovative technology that ensures maximum protection of wood and emphasises the aesthetic values of the raw material.

Handmade trims



Taking care of the finished products, the windows have the handmade trims that are essential to highlight the natural beauty of wood.

Mechanical processing



Window elements that has previously been subject to processing are automatically impregnated, then dried and polished. Afterwards, these elements are glued in specialized presses and transferred to powder paint shop.



COLOURS OF TIMBER PRODUCTS



DURABILITY AND AESTHETICS

COLOURS OF WINDOWS AND DOORS

Transparent colours: _____

pine, larch



Pine*



Light oak



Old pine



Nut



Chocolate brown



Mahogany



Teak

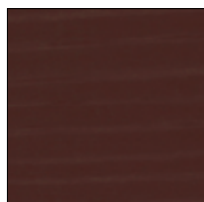

Palisander

Transparent colours: _____

meranti



Pine*



Light oak



Old pine



Nut

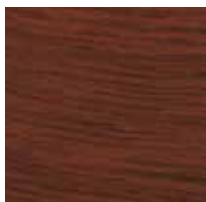

Chocolate brown

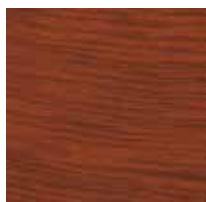

Mahogany



Teak



Palisander

Covering colours: _____

pine, larch, meranti



White

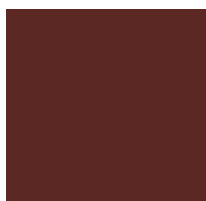

Brown

Optional colours: _____



Any RAL colour

*Not available in plate doors

DREAMS NEED AN IDEA...

That is why we created HarmonyLine - the idea whereby your dream of a beautiful home becomes a reality.

Visit our website
and download
HarmonyLine folder
www.dako.eu



HarmonyLine is a unique idea of a common design of windows, doors, garage doors and roller blinds. This idea allows our clients to find a solution matching the individual character of the building.



THE EXEMPLARY COMPOSITIONS OF HarmonyLine

1^A

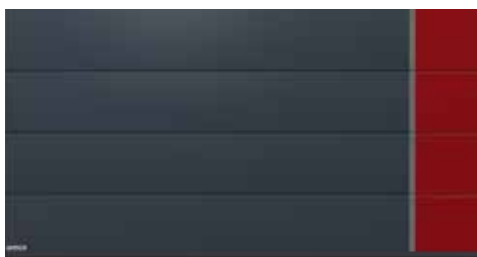

EUNIKA COMPOSITION

4^A

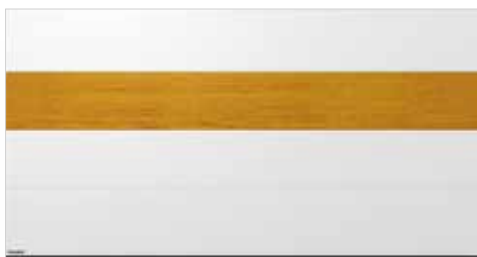

NILA COMPOSITION

7^A

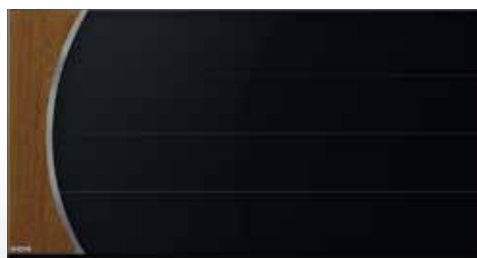

LILLA COMPOSITION

10^A



TAIDA COMPOSITION

...DEFINITE STEPS MAKE IDEAS ALIVE

Therefore, we designed **12 COMPLETE CARPENTRY SETS** of HarmonyLine, in popular configurations and dimensions.

- ◆ **12** ready-made compositions prepared by DAKO designers
- ◆ **5** colour variations of each set
- ◆ **3** materials: **PVC, ALUMINIUM, TIMBER**

WINDOWS | ROLLER BLINDS | DOORS | GARAGE DOORS
PVC | TIMBER | ALUMINIUM



Harmony line

Every single day
around the
world...

thousands of people test DAKO products in the most demanding testing ground – the laboratory of the real life. DAKO products are used, among others, by people of modern and exotic Japan or living in historical capitals of Europe as well as cold, far north and hot regions of Southern America.



www.dako.eu



Find out more:

All information about DAKO policy, quality as well as the pictures of DAKO products and informative articles can be found on the website www.dako.eu